

Formidlings- mysterier

Bidrag til belysning
af materialitet og narrativitet
i museums- og kulturarvsformidling

Jonas Abkjær Andersen
Roskilde Universitet &
Vikingskibsmuseet i Roskilde
23.10.2015



Afhandlingens fokus

- Stoflighed
- Narrativbegrebet
- Fænomenologisk perspektiv

Hidtil uafklarede forskningsmæssige aspekter:

“[M]ateriality and material culture seems to have hardly anything to say about materials [...]. To understand materiality, it seems, we need to get as far away from materials as possible.”

Ingold 2007, 1



Hidtil uafklarede forskningsmæssige aspekter:

“In museum-based studies of material culture in particular, however, it is perhaps especially remarkable that more work has not focused on the physical and sensory attributes of objects and their implications for the uniqueness, actual and potential, of the museum experience.”

Dudley 2012, 5



Der er forskningsmæssig efterspørgsel efter:

- Undersøgelser af stoflighed
- Undersøgelse af forhold mellem stoflighed og mening

Empirisk materiale

Tre perioder:

| | |
|------------------------|-------------------|
| Pilotfeltstudie | 16 |
| Hovedfeltstudie | 96 |
| Supplerende feltstudie | 4 |
| <u>I alt</u> | <u>116 forløb</u> |

Forløb omfatter:

| | |
|--------------------------|-------------------|
| Interview m. observation | 78 |
| Observation u. interview | 38 |
| <u>I alt</u> | <u>116 forløb</u> |

Interviewede personer:

| | |
|---------------------------|--------------------|
| Ansatte og tilknyttede | 32 |
| Publikum | 55 |
| <u>Interviewede i alt</u> | <u>87 personer</u> |

| | |
|-----------------------|--|
| Antal nationaliteter: | 20 |
| Alder og besøgstype: | 25-78 år. Par og mindre, selvorganiserede, grupper |
| Andet materiale: | 82 interne og eksterne dokumenter samt anden dokumentation |

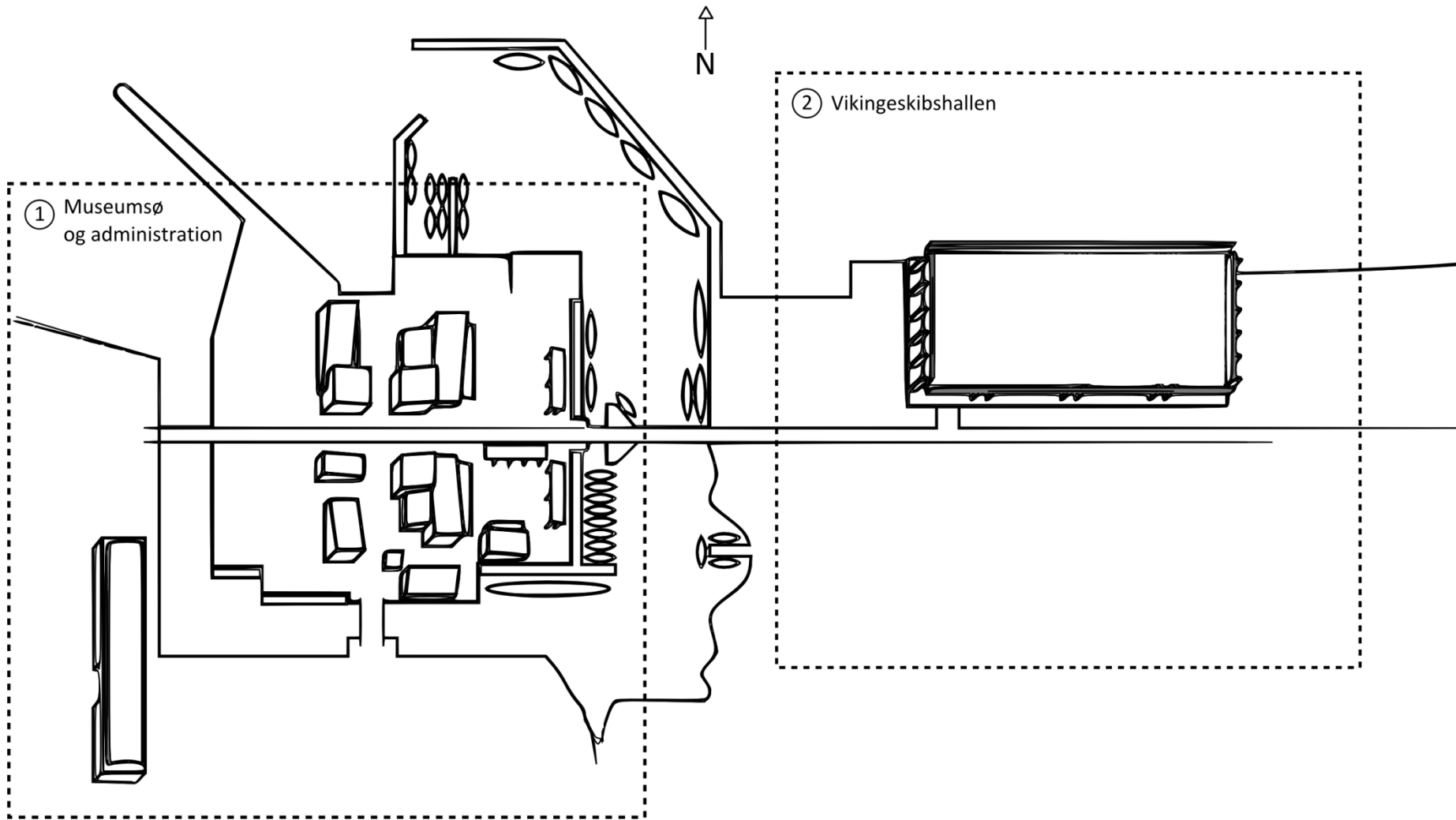

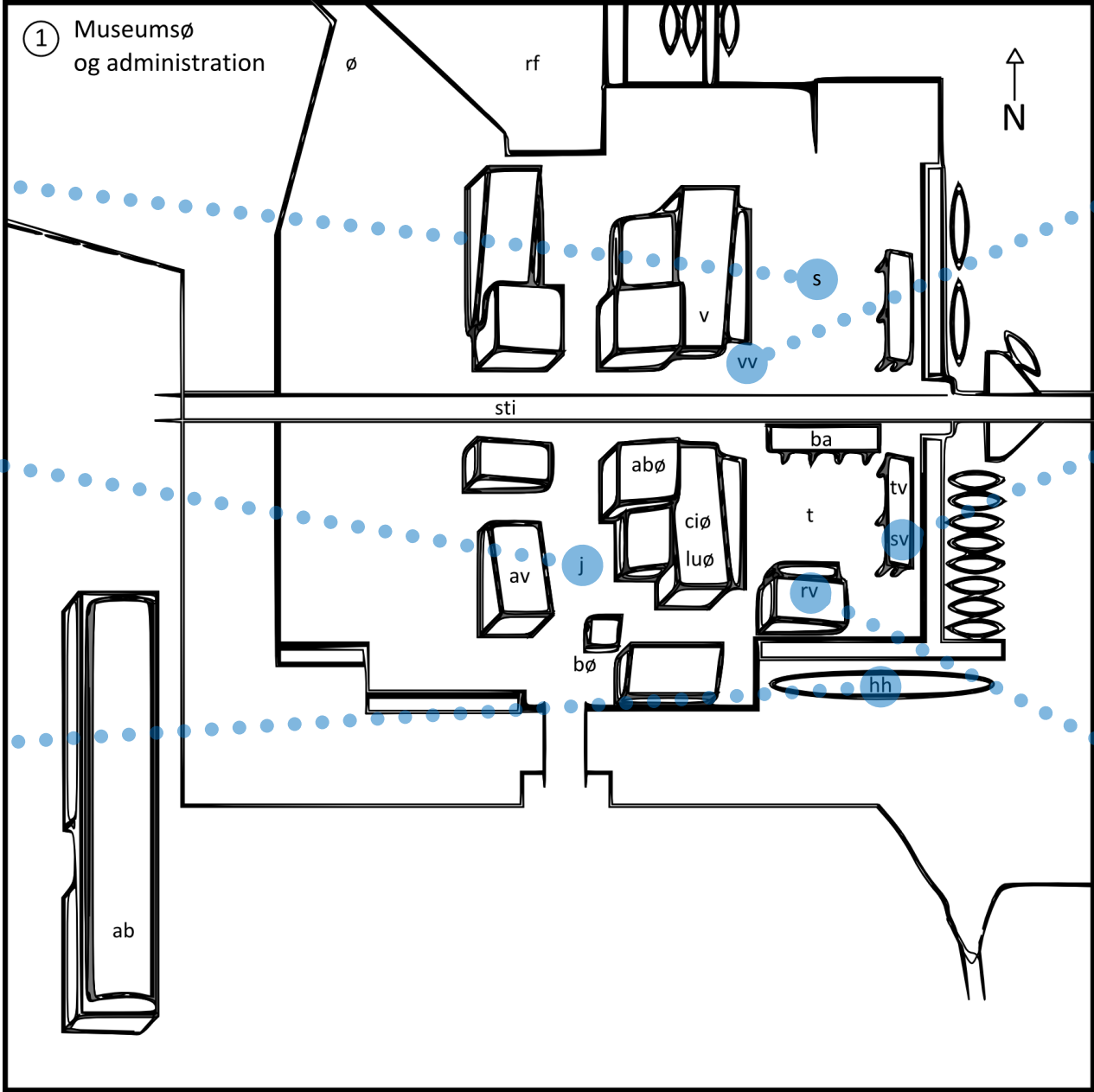

② Vikingeskibshallen

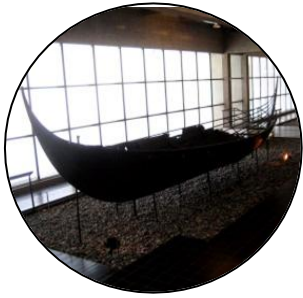
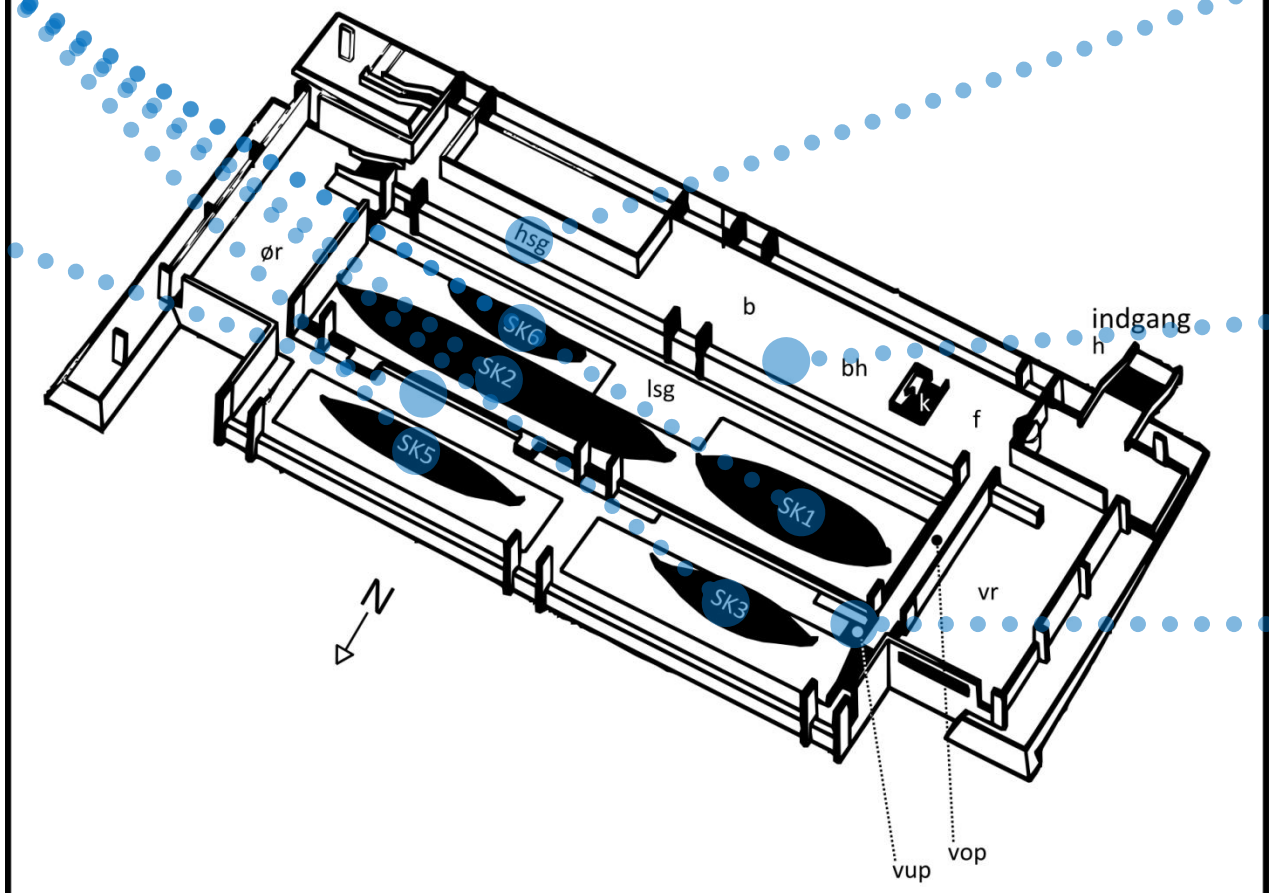

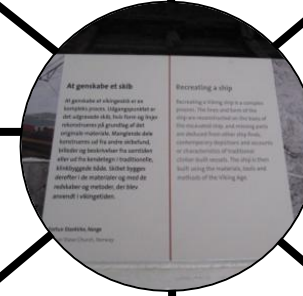
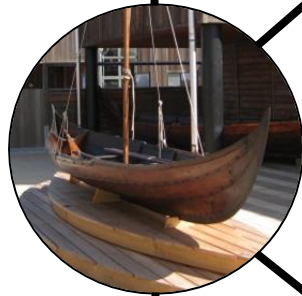



Relationer mellem narrativitet og materialitet

narrative niveauer



forbindelser og brud



materialitet og stoflighed

mysterium

Fund, resultater og bidrag

Eksempler på empiriske fund

- Hånden og stofligheden
- Konkretisering og abstraktion

Stoflighed og mysterium

- Stoflighed. Mere detaljerede analyser af stofligheder
- Mysterium. Hvordan stoflighedens tilstedeværelse og egenskaber har betydning i formidlingen

